

SILVERTON SVT20

08/35674/0 Issue 3

Table of Contents

Welcome and Congratulations	2
Important Instructions	3
Site Selection and Preparation	4
Log Grate Assembly.....	6
Log Grate Installation.....	11
Operation	12
Maintenance	13
Additional Information	14
Troubleshooting	15

Always use a qualified technician or service agent to repair this Log grate

Note: Procedures and techniques that are considered important enough to emphasise

Caution: Procedures and techniques which, if not carefully followed, will result in damage to the equipment

Warning: Procedures and techniques which, if not carefully followed, will expose the user to risk of fire, serious injury or death.

The sump and the water tank in this product are treated with a biocidal product, Silver Biocide. This conforms with the latest relevant ISO standard

Welcome and Congratulations

Thank you and congratulations for choosing to purchase a Silverton from Dimplex.

Please carefully read and save these instructions.

Caution: Read all instructions and warnings carefully before starting installation. Failure to follow these instructions may result in a possible electric shock, fire hazard and will void the warranty

Please record your model and serial number below for future reference: model and serial number can be found on the Model and Serial Number Label located on the side of the Silverton

Model Number: _____

Serial Number: _____

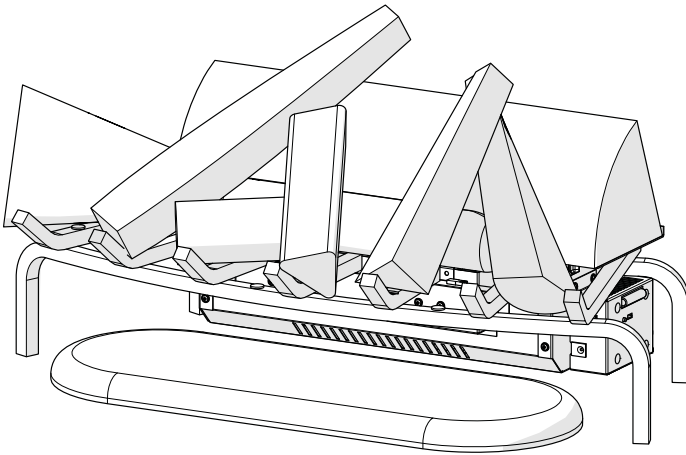

Important Instructions

Please read this information guide carefully to be able to safely install, use and maintain your product

When using electrical appliances, basic precautions should always be followed to reduce the risk of fire, electrical shock and injury to persons, including the following:

1. WARNING

This appliance carries a DO NOT COVER warning. Do not place material or garments on, or obstruct the air circulation around the appliance.

2. DAMAGE

If the appliance is damaged, check with the supplier before installation and operation.

If the supply cord is damaged it must be replaced by the manufacturer or service agent or a similarly qualified person in order to avoid a hazard.

3. LOCATION

Do not use outdoors.

Do not use in the immediate surroundings of a bath, shower or swimming pool.

Do not locate the fire immediately below a fixed socket outlet or connection box.

Ensure that furniture, curtains or other combustible material are positioned no closer than 1 metre from the appliance.

4. PLUG POSITIONING

The appliance must be positioned so that the plug is accessible.

Keep the supply cord away from the front of the appliance.

5. UNPLUGGING

In the event of a fault unplug the device.

Unplug the device when not required for long periods.

6. OWNER/USER

This appliance can be used by children aged from 8 years and above and persons with reduced physical, sensory or mental capabilities or lack of experience and knowledge if they have been given supervision or instruction concerning use of the appliance in a safe way and understand the hazards involved. Children shall not play with the appliance. Cleaning and user maintenance shall not be made by Children without supervision.

Children of less than 3 years should be kept away unless continuously supervised. Children aged from 3 years and less than 8 years shall only switch on/off the appliance provided that it has been placed or installed in its intended normal operating position and they have been given supervision or instruction concerning use of the appliance in a safe way and understanding the hazards involved. Children aged from 3 years and less than 8 years shall not plug in, regulate and clean the appliance or perform user maintenance.

7. ELECTRICITY

Before switching on, please read the safety advice and operating instructions.

Note: This appliance is only to be used with the power supply unit provided.

Only plug this appliance into a supply that corresponds to that displayed on the power supply unit. The appliance must only be supplied at extra low voltage corresponding to the markings on the appliance

CAUTION - Some parts of this product can become very hot and cause burns. Particular attention has to be given where children and vulnerable people are present.

This instruction can be found at WWW.DIMPLEX.CO.UK

8. USAGE

Do not burn wood or other materials in the log grate

Site Selections and Preparation

This section provides instructions for selecting a location and preparing the site to install the Log Grate

1. Select a suitable location that ensures the Log Grate is sitting on a hard level surface for optimum flame effect
2. Allow for approximately 5cm of clearance behind the unit (from the frame to the back of the mantle) and 20cm directly above the back log to allow for removal of the Refill Container.
3. Carefully unpack all of the components from the box.

Caution: Handle the logs carefully, that are fragile and can easily crack or break if dropped.

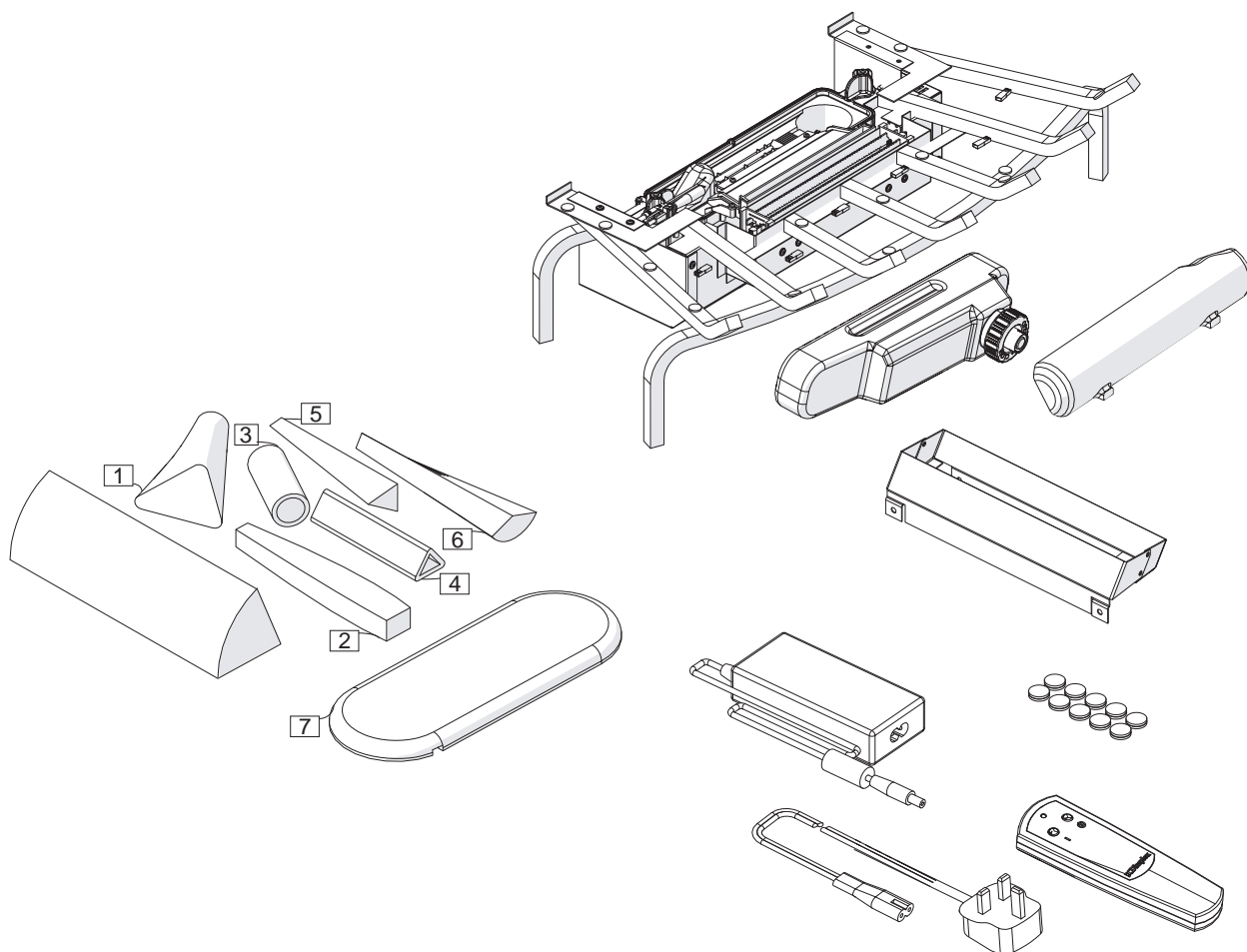
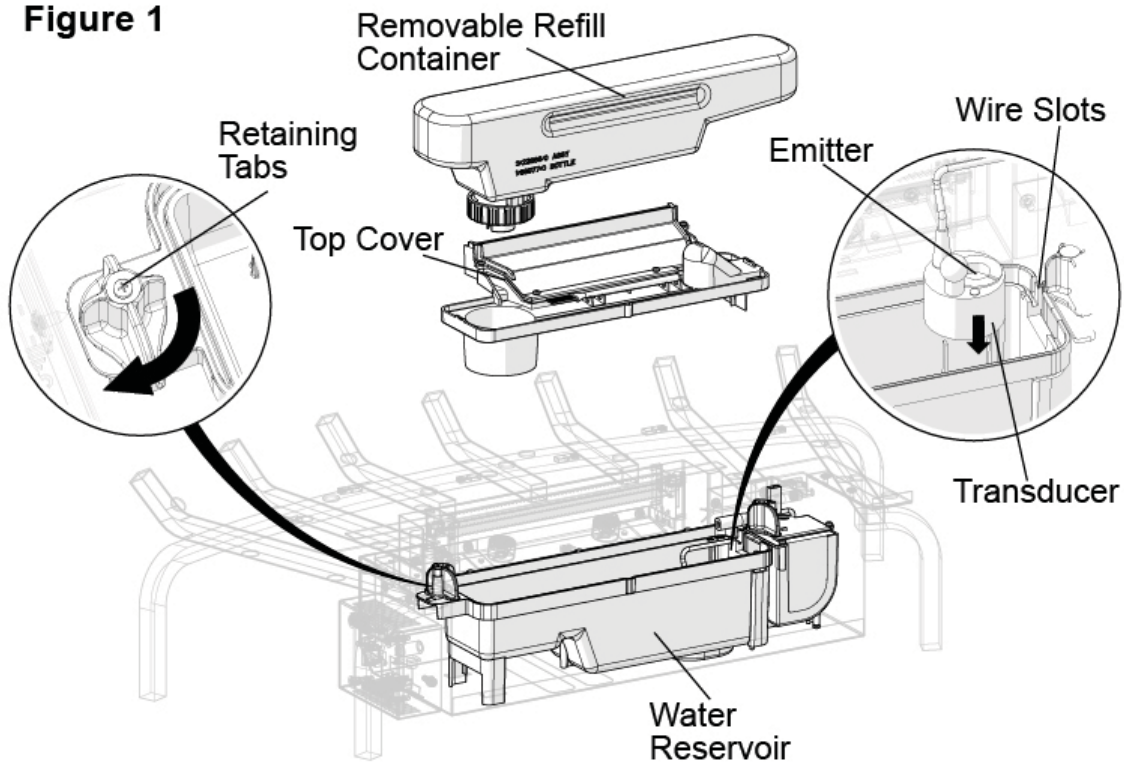

Figure 1



4. Unpack the transducer (contained within the water reservoir) which has been wrapped to protect it during shipping. See Figure 1.

To access the transducer;

- Remove the top cover by turning the retaining tabs on both ends of the water reservoir.
- Remove any packaging material.
- Install the transducer so that it is sitting level in the circular holding area in the reservoir.
- Orientate the transducer wire so that it does not sit directly above the Emitter and the wire passes through the slit in the side of the tank.
- Reinstall the top cover and ensure both retaining tabs have been turned so that they are pointing inwards.

Note: Completely assemble the unit before filling the water

Log Grate Assembly

1

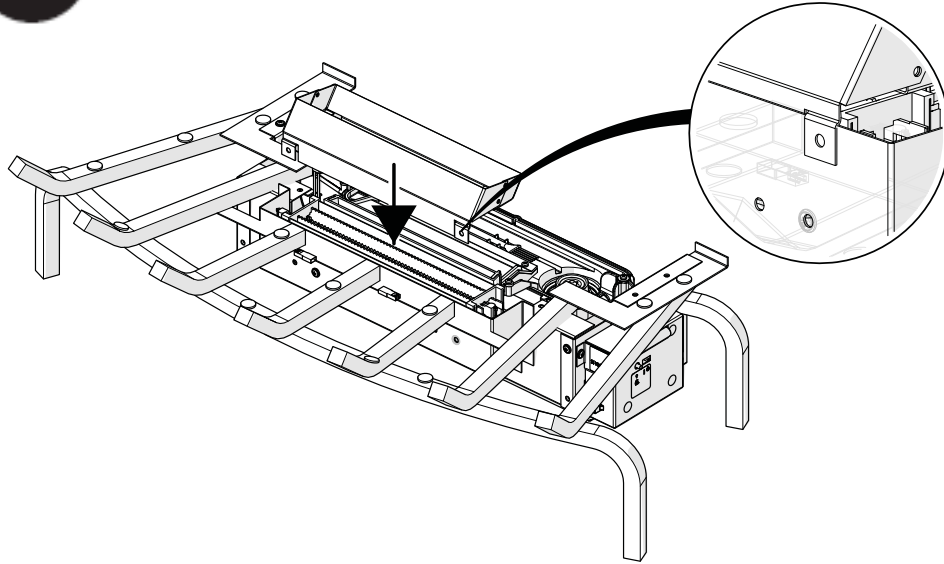

Caution: Handle logs carefully, they are fragile and can easily crack or break, if dropped.

2

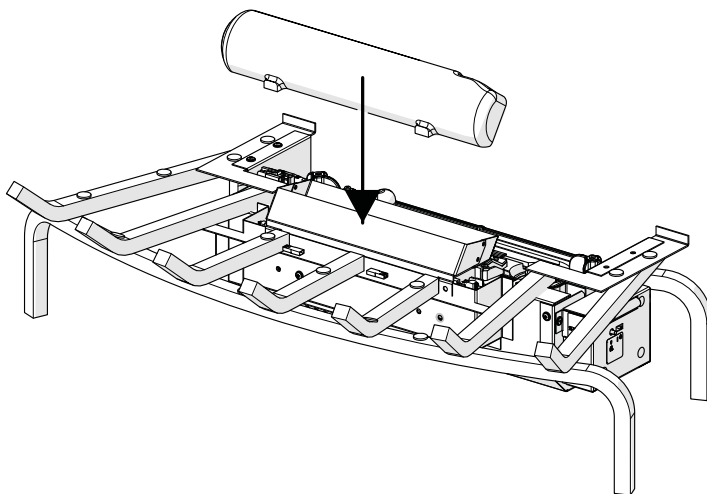

Log Grate Assembly

Each log is a separate component that needs to be placed on the grate. Position each log so that the hook and loop pad on the backside of the log lines up with the corresponding hook and loop pad on the log grate. These pads assist with securing the logs to the grate.

Note: Each of these logs are hand made, and as such, the hook and loop pads on the logs and grate may not align perfectly, therefore, we have included additional pads should you need to reposition them.

Each of the logs contain LED lights to create a flickering effect. During the assembly, each log requires the electrical connectors on the log and grate to be connected as they are being placed. In some cases, these wires can have tie wraps added to prevent the wires from being seen after final assembly. (not included)

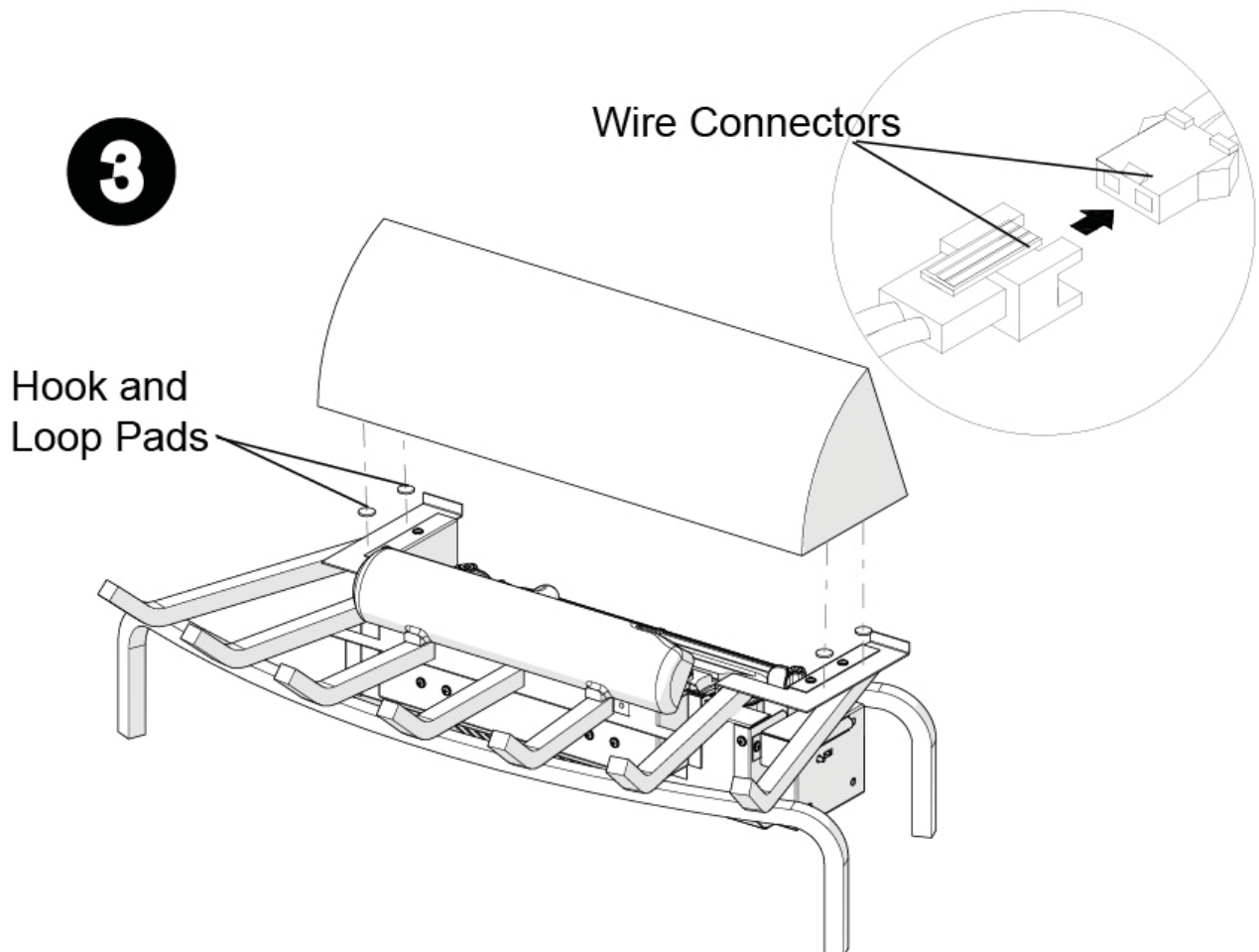

Log Grate Assembly

4

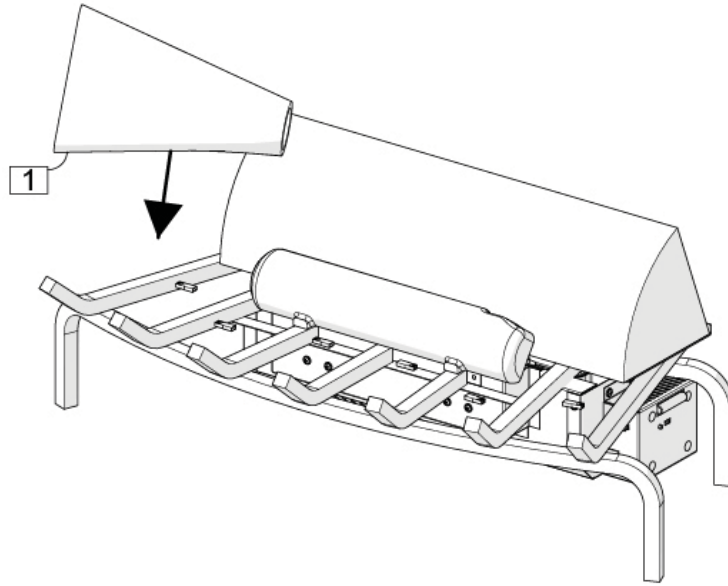

5

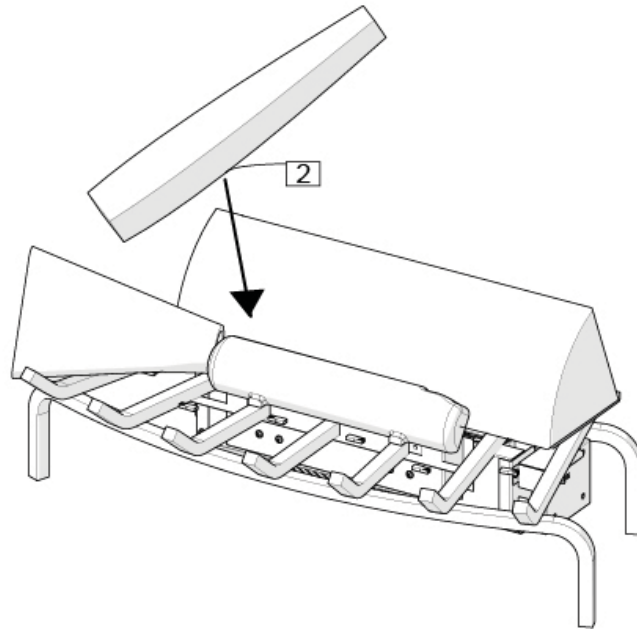

6

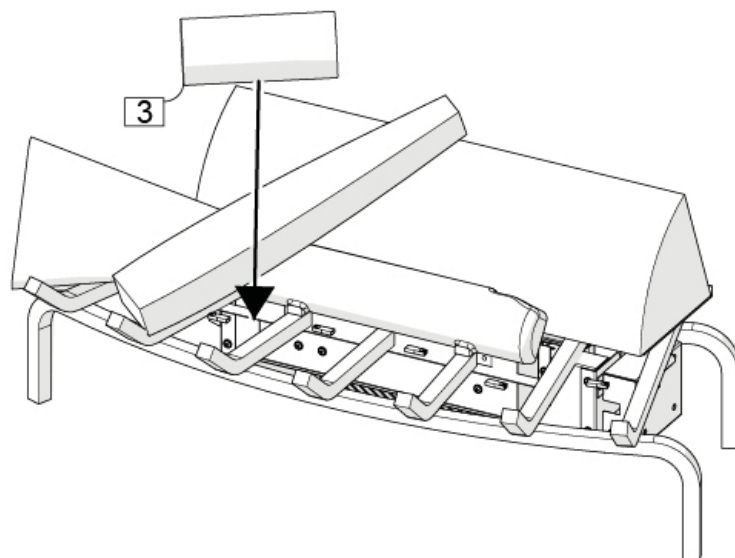

7

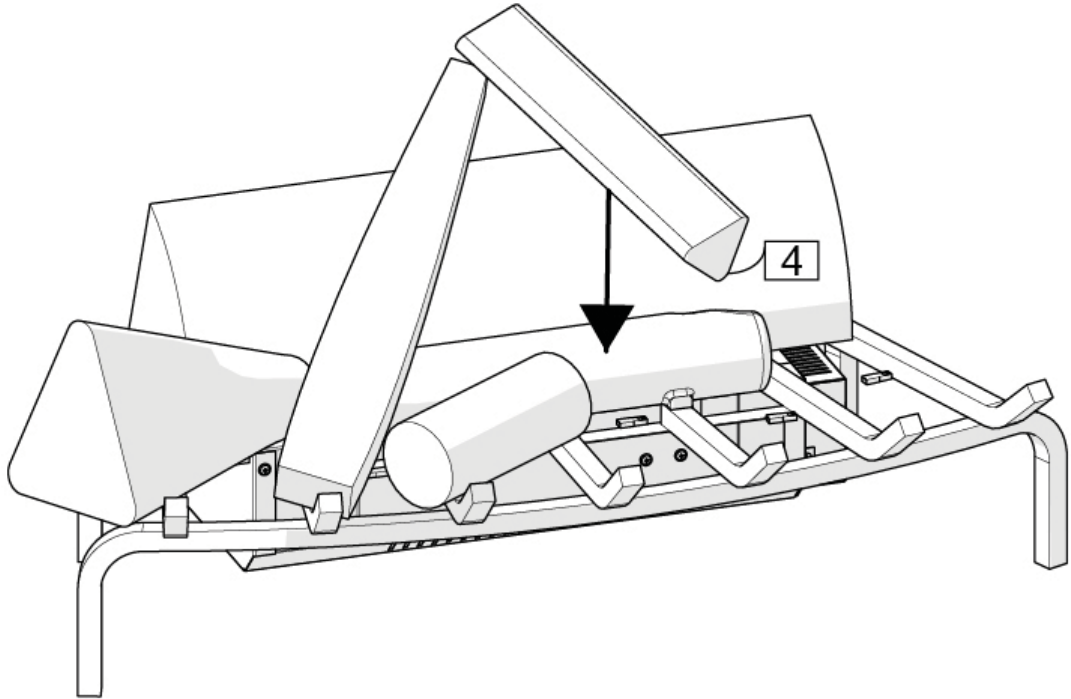

8

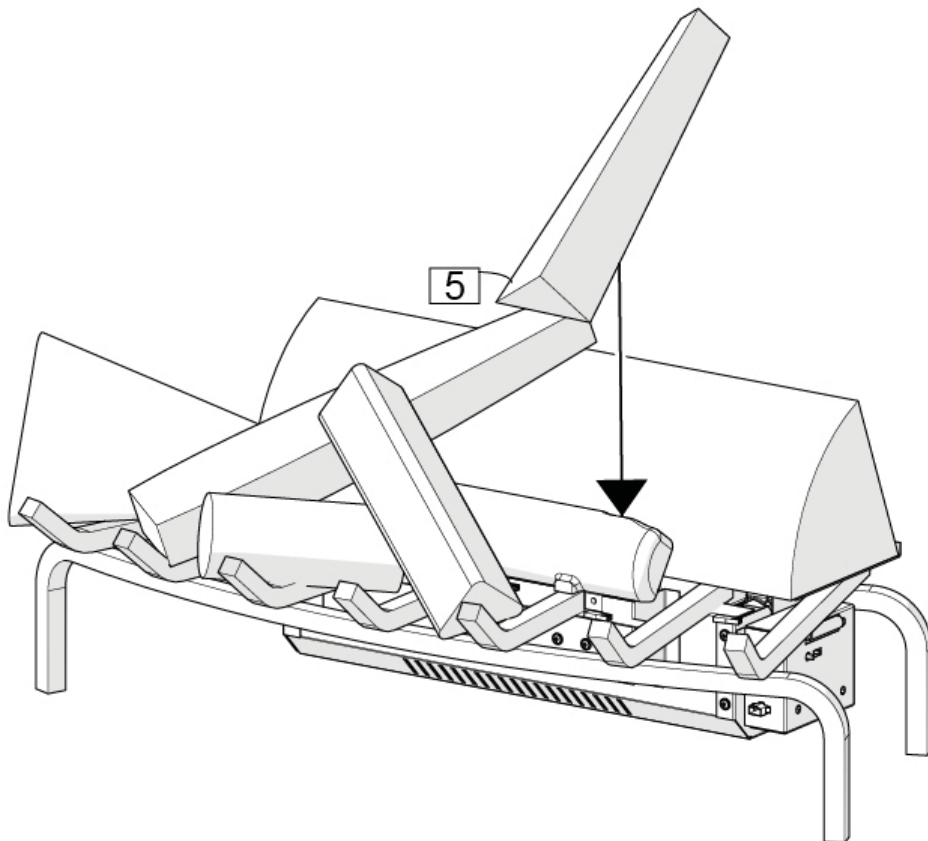

9

Caution: Ensure that the logs are placed so that they are not blocking the flame effect outlet

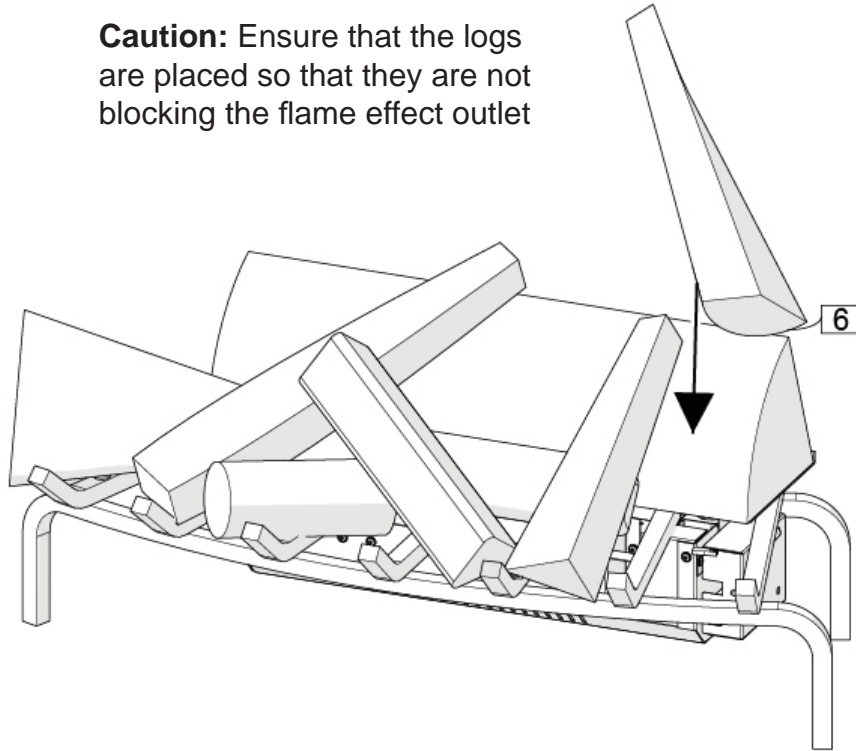

10

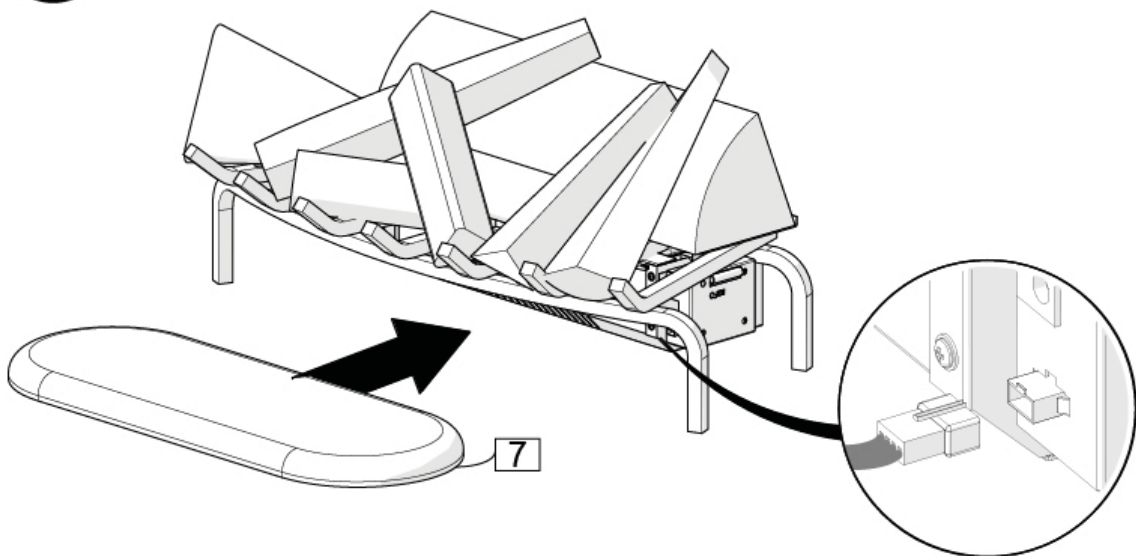

Log Grate Installation

Only use filtered tap water in this appliance.

Once installed, never move this appliance or lay it on its back, without draining the water from the sump and water tank.

If you intend not using the appliance for longer than 2 weeks, drain the water from the reservoir and refill container.

The refill container, reservoir, cover and container cap must be cleaned once every two weeks, particularly in hard water areas.

1) Fill and install the Refill Container.

Note: During initial installation, the Refill Container should be refilled after the Reservoir has filled to ensure maximum operation time.

2) Make sure the On/Off switch is switched to Off (refer to Operating Instruction section)

3) Assemble power adaptor (Figure 2). Plug the power adaptor into the front of the unit, then plug the unit into a power socket

Figure 2

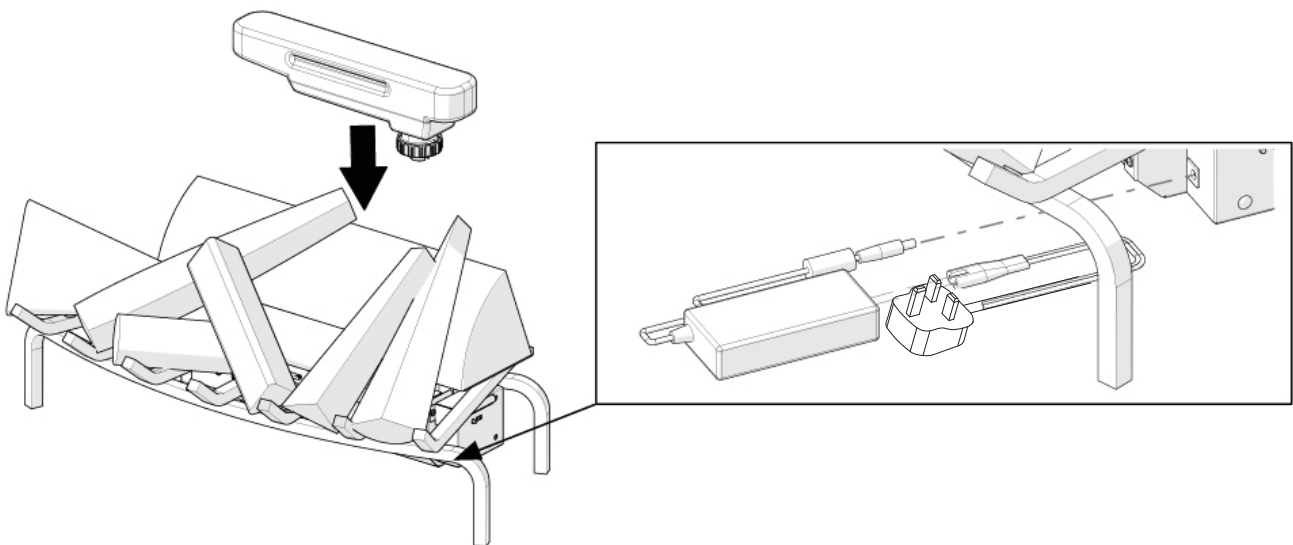
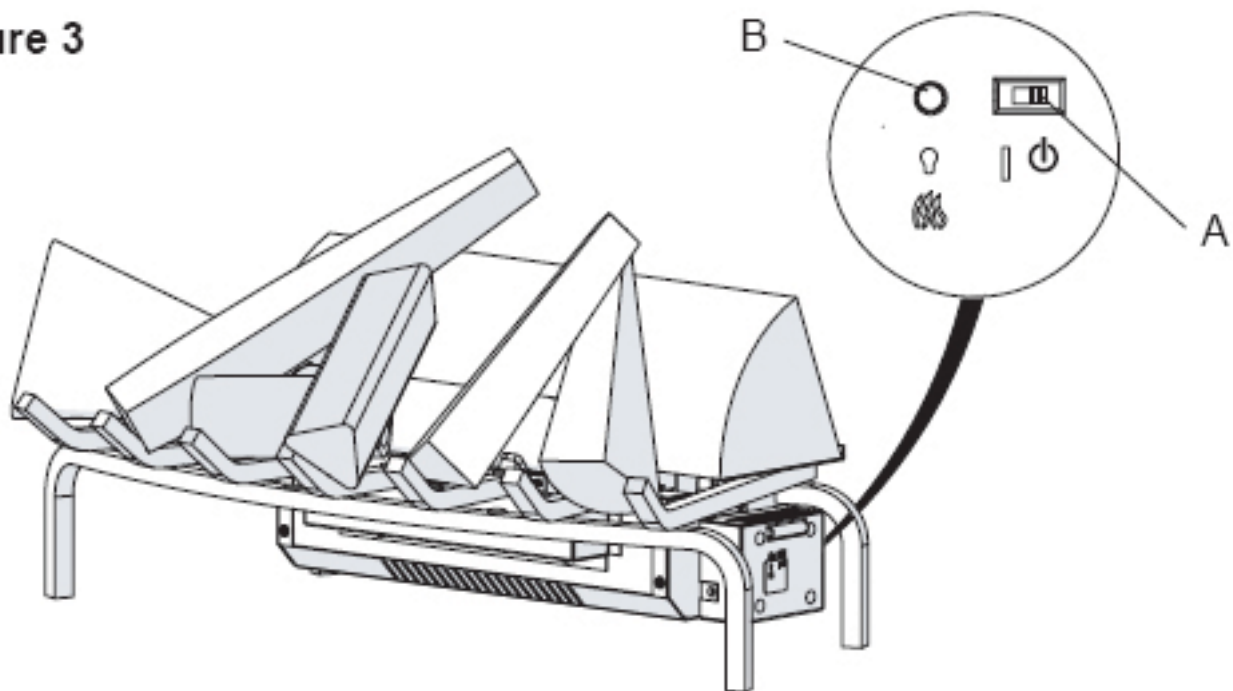

Figure 3



The manual controls for the Log Grate are located on the right side (Figure 3).

A. On /Standby Switch.

Supplies power to the Log Grate

B. Momentary Button

Pressing this button toggles between Logs, Logs and flame effect, and Off.

Remote Control

The unit is supplied with a radio frequency remote control. This remote control has a range of approximately 15m. It does not have to be pointed at the fireplace and can pass through most obstacles (including walls). It is supplied with one of 243 independent frequencies to prevent interference with other units. The frequency designation is indicated on the back of the remote control.

Note: Before attempting any operation with the remote control, pull the plastic insulator strip out from between the remote casing and the battery cover (Figure 4).

Remote Control Initialisation/Reprogramming

Follow these steps for remote control initialisation and if required, re-initialisation;

1. Unplug the power adaptor from the unit.
2. Wait a minimum of five seconds and then plug the power adapter back into the unit
3. Within ten seconds of re-acquiring power, press the ON button located on the remote control (Figure 4)

This will synchronize the remote control and the receiver

Remote Control Usage

Pressing the On button, on the remote control, switches between the two levels:

Level 1: The Logs and lights are turned on.

Level 2: The logs and lights remain on and the flame effect is activated.

The fireplace can be turned off at any point by pressing the OFF button on the remote control.

Note: Once the mist has been activated, the unit will have to be turned Off, using either the momentary button, on the unit, on the Off button or the remote control, then back on to return to Level 1 - Logs and Lights only in operation.

Battery Replacement

To replace the battery,

1. Slide the battery cover open on the remote control (Figure 4)
2. Install one 12v (A23) battery in the battery holder
3. Close the battery cover

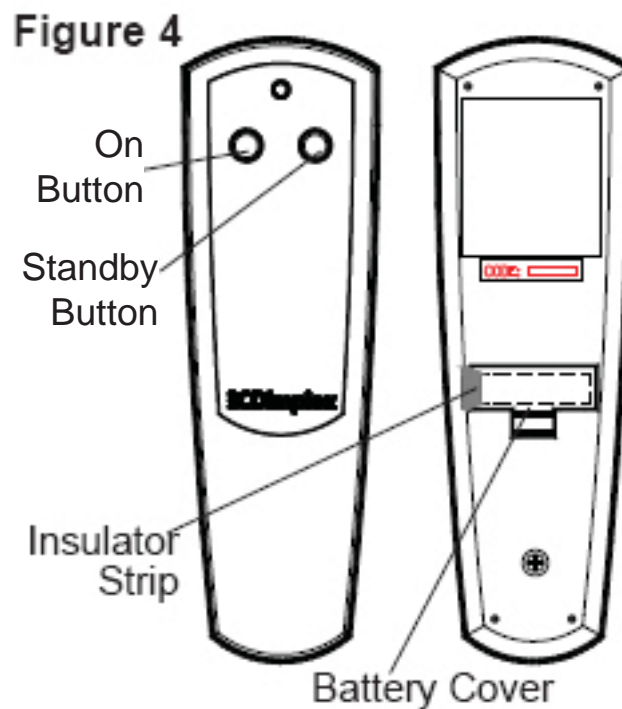

Maintenance

Warning: Disconnect the power before attempting any maintenance or cleaning to reduce the risk of fire, electric shock or damage to persons.

Log Grate Surface Cleaning

Use a warm damp cloth only to clean surfaces of the Log Grate. Do not use abrasive cleaners.

Water Reservoir

Note: There is no need to remove any of the logs or move the unit to access the water storage system. However if you decide to move the unit to perform any cleaning, ensure that the logs are stable before cleaning.

The water storage system is located behind the back log. It can easily be removed by lifting each of the components directly up. (Figure 5).

Note: There are tabs, on each end, that need to be turned to release the component

Caution: Only filtered tap water should be used in the unit to prevent scaling of the components

If you do not intend on using the unit for longer than two weeks, empty and drain the unit of water, and dry all of the water containing components.

It is recommended that all of the water containing components are cleaned with soap and water

on a **biweekly** basis. A small brush has been included to assist in cleaning difficult items/areas i.e. the transducer

Caution: Do not put plastic components into the dishwasher.

Note: If you need to move the unit ensure that all of the components that contain water have been emptied before relocating.

Figure 5

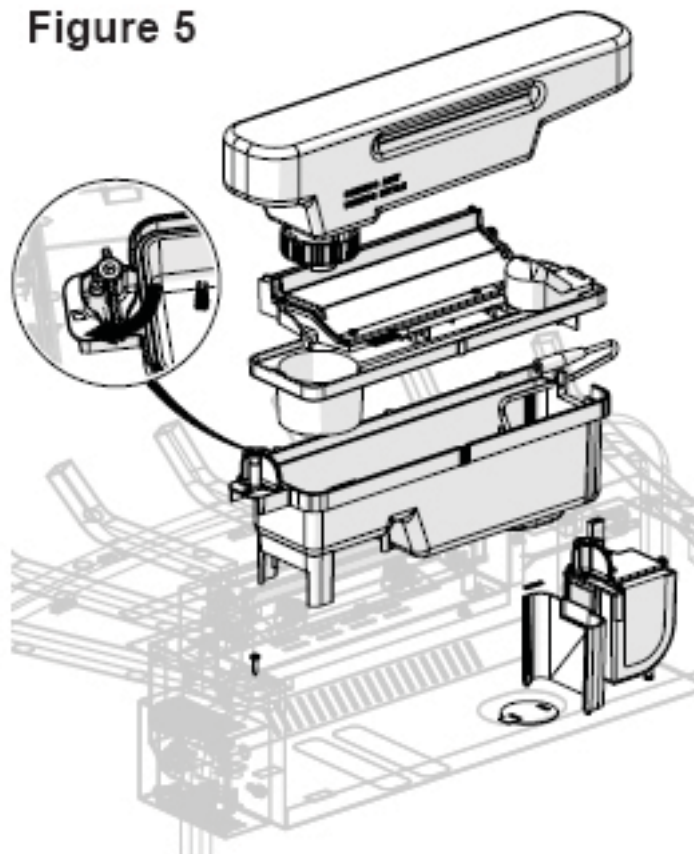

Additional Information

AFTER SALES SERVICE

Your product is guaranteed for one year from the date of purchase. Within this period, we undertake to repair or exchange this product free of charge (excluding lamps & transducer disc and subject to availability) provided it has been installed and operated in accordance with these instructions. Your rights under this guarantee are additional to your statutory rights, which in turn are not affected by this guarantee.

Should you require after sales information or assistance with this product please go to www.dimplex.co.uk and select "Customer Support" or ring our help desk on 0844 879 3589 (UK) or 01 842 4833 (R. O. I.). Spare parts are also available on the web site. Please retain your receipt as proof of purchase.

RECYCLING



For electrical products sold within the European Community - At the end of the electrical products useful life it not be disposed of with household waste. Please recycle where facilities exist. Check with your Local Authority or retailer for recycling advice in your country.

PATENT / PATENT APPLICATION

Products within the Optimyst range are protected by one or more of the following patents and patent applications:

Great Britain GB 2402206, GB 2460259, GB 2460453 , GB 2418014, GB 2465738, GB 2449925, GB 2465537 , GB 2455277 , GB1020534.2, GB1020537.5, GB1110987.3

United States US 7967690, US 2010299980, US 2011062250, US 2008028648, US 13/167,042

Russia RU2008140317

European EP 2029941, EP 2201301, EP 2315976, EP 1787063, EP07723217.1 , EP11170434.2, EP 11170435.9

China CN 101883953, CN 200980128666.2, CN 101057105, CN 101438104

Australia AU 2009248743, AU 2007224634

Canada CA 2725214, CA 2579444, CA 2645939

International Patent Application WO 2006027272

South Africa ZA 200808702

Mexico MX 2008011712

Korea KR 20080113235

Japan JP 2009529649

Brazil BR P10708894-9

India IN 4122/KOLNP/2008

New Zealand NZ 571900

Troubleshooting

Symptom	Cause	Corrective Action
The flame effect will not start.	Mains plug is not plugged in. Low water level. Low voltage connector not connected properly. (See Fig.5) The Transducer Unit is not sitting correctly in the sump	Check plug is connected to wall socket correctly. Check that the water tank is full and there is water in the sump. Check that the connector is inserted correctly. (See Fig.5) Ensure the Transducer is sitting down into the moulded recess in the sump
The flame effect is too low.	The Metal Disc in the transducer might be dirty. The wire from the Transducer Unit is sitting over the metal disc	Clean the Metal Disc with soft brush supplied. See 'Maintenance.' for a step by step procedure. Direct the wire to the back of the sump and make sure it sits into the side slot exiting the sump.
Unpleasant smell when unit is used.	Dirty or stale water. Using unfiltered tap water.	Clean the unit as described under maintenance. Use only filtered tap water.
Main lamps are not working and there are no flames or smoke.	There is no water in the water tank	Follow instructions under Maintenance , 'Filling the water tank'. Check the plug is connected to the wall socket correctly and that Switch 'A' Fig. 3 is in the 'ON' (I) position.

OPTIMYST is a trade mark of GDC Group Ltd.

GDC Group Ltd.
MILLBROOK HOUSE
GRANGE DRIVE
HEDGE END
SOUTHAMPTON
SO30 2DF

TEL: 0844 879 3589
FAX: 0844 879 3583
WEBSITE: www.dimplex.co.uk
Republic of Ireland Tel. 01 8424833

© GDC Group Ltd,
All rights reserved. Material contained in this publication may not be reproduced in whole or in part, without prior permission in writing of Dimplex.
A division of GDC Group Ltd.