

# N21

## Naturstein klassisch



Abbildung: N21  
Naturstein (zweifarbzig): Rojo Alicante mit Crema Marfil

### Standard



Tür schwenkbar  
Anschlag li./re.



Front Kristall

### Gesamtgewicht



ca.  
370 kg

### Kamineinsatz

Lina 6757 s  
NW-Leistung: 9 kW  
Abgasstutzen: Ø 180 mm

### Optional



Tür  
hochschiebbar



Doppel-  
verglasung



Mehr Infos unter  
[camina-schmid.de](http://camina-schmid.de)

### Zubehör



Heizwasser-  
Aufsatzregister R



Aufsatz-  
speicher



Warmluft-  
Aufsatzregister



Nachheiz-  
kasten



SMR



Elektronischer  
Türantrieb



Blockstein-  
Anlage



Vorlegeplatte

### Naturstein

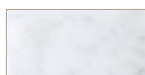

Blanco Carrara

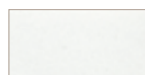

Blanco Macael

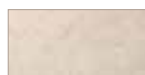

Crema Marfil



Negro Abanilla



Rojo Alicante



Rosa Claro

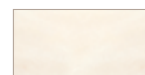

Rosa Crema



Marron  
Emperador

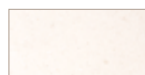

Blanco  
Nacarado



Caliza Moka



Travertino  
Romano

Frontansicht M 1:25

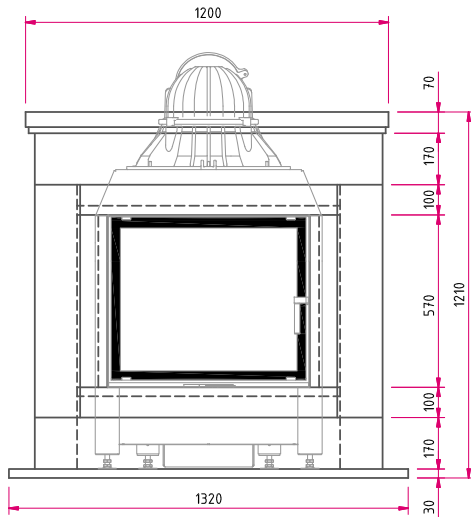

Seitenansicht M 1:25

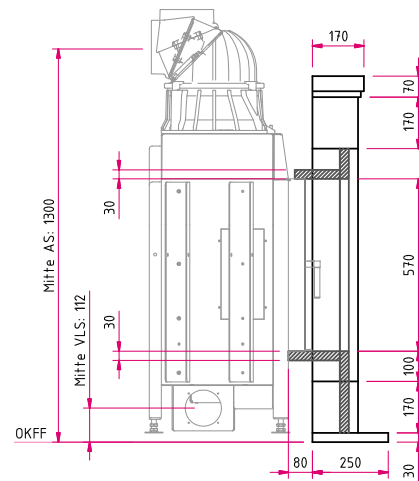

Hinweis: Mit **optionalem Zubehör** bitte die Angaben in den Preislisten beachten.  
AS: Abgasstutzen, VLS: Verbrennungsluftstutzen, OKFF: Oberkante Fertigfußboden

Draufsicht M 1:25

